

REVISIONS			
REV.	DESCRIPTION	DATE	APPROVED
0	RELEASED FOR PRODUCTION	6/15/05	ON FILE
D	INCORPORATED REV D XP2I	10/16/12	ON FILE
E	INCORPORATED REV E XP2I	7/29/2013	ON FILE

**SPECIFICATIONS**

**PRESSURE:** SEE AVAILABLE PRESSURE RANGES CHART

**ACCURACY:**  
 0% TO 20% OF FULL SCALE: ±0.02% OF FULL SCALE  
 20% TO 100% OF FULL SCALE: ±0.1% OF READING

**VACUUM:** (ONLY APPLIES TO 300 PSI AND BELOW GAUGES)  
 0 TO -14.5 PSIG: ±0.25% OF FULL SCALE (-14.5 PSI)

**POWER:** 3 AAA ALKALINE BATTERIES

**PRESSURE CONNECTION:** 1/8"-27 FEMALE NPT

**ELECTRICAL INTERFACE:** DB9F CONNECTOR, RS232

**ENCLOSURE:** NICKEL-PLATED ALUMINUM ALLOY CASE, "AUTOFLEX-EBG10" POLYESTER MEMBRANE SWITCH PANEL, ABS REAR COVER.

**WEIGHT:** 2.7 lbs (1.25kg)

**PRESSURE PORT MEDIA COMPATIBILITY:** LIQUID AND GASES COMPATIBLE WITH 303 STAINLESS STEEL SENSOR MANIFOLD; 316 STAINLESS STEEL SENSOR; PTFE TAPE

**OPERATING AND COMPENSATED TEMPERATURE RANGE:** -10°C TO +50°C (14°F TO 122°F).

**STORAGE TEMPERATURE RANGE:** -20°C TO +70°C (-4°F TO 158°F).

**CERTIFICATIONS:** NONE

SPECIFICATIONS SUBJECT TO CHANGE WITHOUT NOTICE.

AVAILABLE PRESSURE RANGES CHART			
UNIT OF MEASURE	PRESSURE RANGE	GAUGE P/N	ABSOLUTE P/N
PSI	15	WT15PSI-1500	-
	30	WT30PSI-1500	-
	100	WT100PSI-1500	-
	300	WT300PSI-1500	-
	500	WT500PSI-1500	-
	1000	WT1KPSI-1500	-
	2000	WT2KPSI-1500	WT2KPSIB-1500
	3000	WT3KPSI-1500	WT3KPSIB-1500
	5000	WT5KPSI-1500	WT5KPSIB-1500
	10000	WT10KPSI-1500	WT10KPSIB-1500
BAR	1	WT1BAR-1500	-
	2	WT2BAR-1500	-
	7	WT7BAR-1500	-
	20	WT20BAR-1500	-
	30	WT30BAR-1500	-
	70	WT70BAR-1500	-
	140	WT140BAR-1500	WT140BARB-1500
	200	WT200BAR-1500	WT200BARB-1500
KPA	100	WT100KPA-1500	-
	200	WT200KPA-1500	-
	700	WT700KPA-1500	-
	2000	WT2KKPA-1500	-
	3000	WT3KKPA-1500	-
	7000	WT7KKPA-1500	-
	14000	WT14KKPA-1500	WT14KKPAB-1500
	20000	WT20KKPA-1500	WT20KKPAB-1500
	30000	WT30KKPA-1500	WT30KKPAB-1500
	70000	WT70KKPA-1500	WT70KKPAB-1500

NOTE: ALL RANGES SHOWN ARE ALSO AVAILABLE IN A -DD (DUAL DISPLAY) VERSION  
 EXAMPLE: WT100KPA-DD-1500

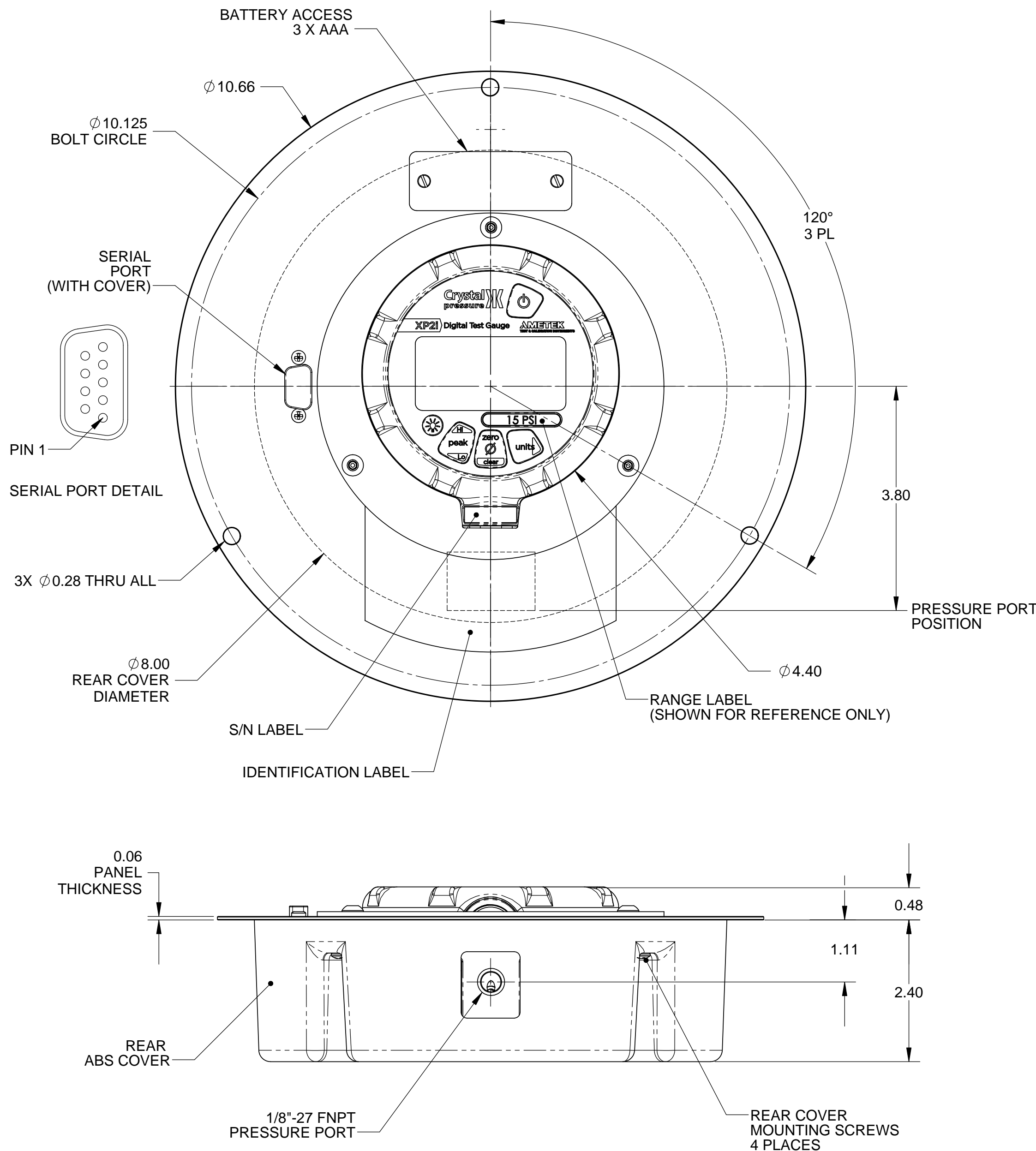

**PROPRIETARY NOTICE**  
 THIS DOCUMENT AND ANY DATA DISCLOSED HEREIN IS THE SOLE PROPERTY OF CRYSTAL ENGINEERING CORPORATION AND MAY NOT BE REPRODUCED, USED OR DISCLOSED IN PART OR IN WHOLE, TO ANYONE WITHOUT THE WRITTEN CONSENT OF CRYSTAL ENGINEERING CORPORATION.

UNLESS OTHERWISE SPECIFIED DIMENSIONS ARE IN INCHES  
 TOLERANCES ARE:  
 FRACTIONS DECIMALS ANGLES  
 .XXX ± .005  
 .XXXX ± .001

**CRYSTAL** (805) 595-5477  
 engineering corporation www.crystalengineering.net

**WT-1500 SERIES GAUGE**

APPROVALS	DATE	SCALE: 1:1	SIZE <b>C</b>	DRAWING NO. <b>3316</b>	REV <b>E</b>
DRAWN M.J.Cain	6/15/2005				
CHECKED D.Porter	6/15/2005				
MFG. ENGR. M.J.Cain	6/15/2005				
Q.A. M.Merrill	6/15/2005	DO NOT SCALE DRAWING		SHEET 1 OF 1	